



PERFORMANCE EXHAUST SYSTEM

APPLICATION

YEAR	MODEL
2009-2014	Kawasaki KLX250

PRODUCT

143002C350	RS2 SS Slip-On Exhaust with Aluminum Sleeve
------------	---

- This product is designed for use in closed course racing and is not intended for highway use. In the state of California, it is illegal to modify the emission control system, which includes the fuel injection of any vehicle.
- You must know how to remove and replace your stock exhaust in order to install this product otherwise have it installed by a professional mechanic. Keep all stock parts from your existing system as some components may be necessary to install your new Yoshimura exhaust depending on the application.
- Read through all instructions before beginning installation. Exhaust system can be extremely hot. Let motorcycle cool down before beginning installation. Always wear hand and eye protection and take precautionary measures to avoid injury.

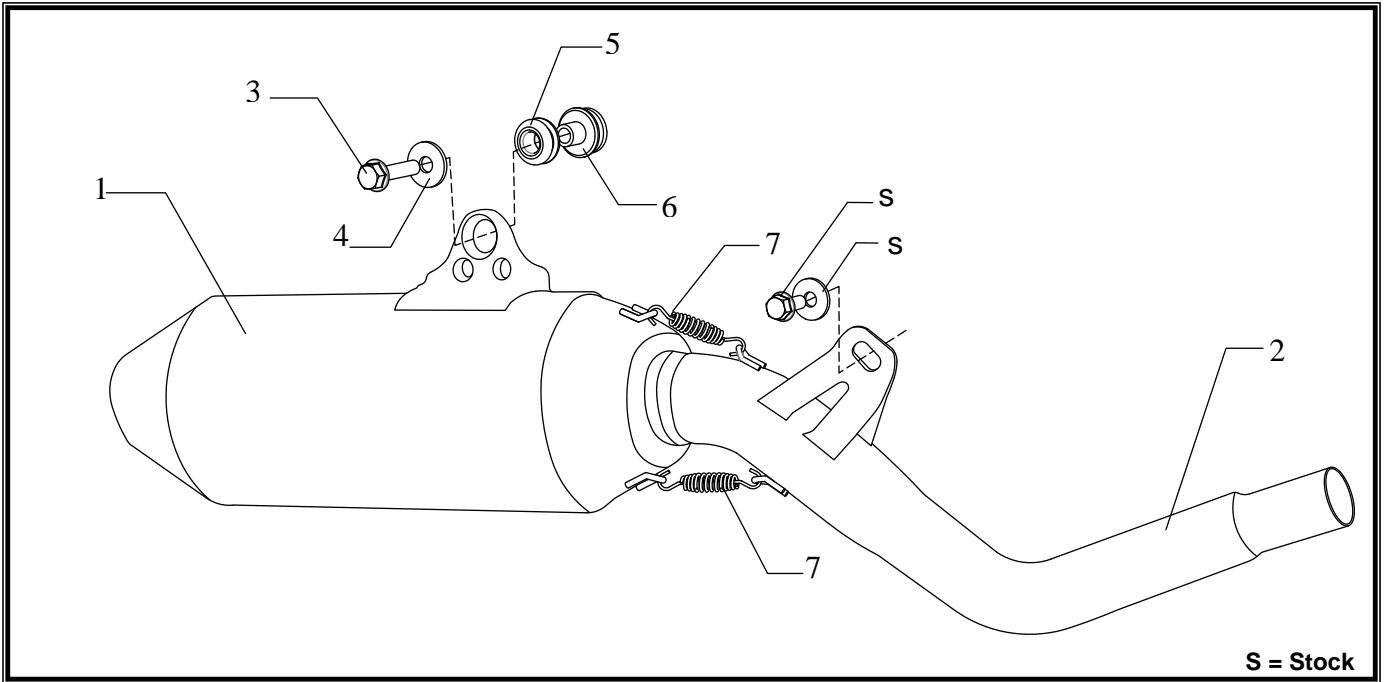

No.	Part #	Description	Qty
1	143002C350-RMA	Yoshimura Muffler	1
2	14300-435	Yoshimura Tailpipe	1
3	M8X35H	8mm x 35mm Flanged Hex Bolt	1
4	8MMWASHERL	8mm Large Washer	1
5	Z1022	Rubber Grommet	1
6	ALS-029	Aluminum Spacer	1
7	RACE-SPX-1	Short Spring	2
**	11061-1055	Exhaust Gasket	1
**	347PLUG	Muffler Wash Plug	1
**	ST-200	Spring Puller Tool	1
**	17029	Yoshimura Sticker Sheet	1

-TOOLS REQUIRED-

Metric Socket Set

Combination Wrench Set

Torque Wrench

Metric Allen Wrench Set

-REMOVAL-

1. *Removing the right side cover.*

- a) **Remove the (3) side cover bolts.**
- b) **Carefully pull off side cover and set aside.**

2. *Removing the muffler.*

- a) **Loosen the muffler clamp on the tailpipe.**
- b) **Remove the (3) bolts that hold the muffler assembly to subframe.**
- c) **Remove the muffler and tailpipe off the stock header.**

-INSTALLATION-

1. *Small parts installation.*

- a) **Install provided rubber grommet into muffler bracket.**
- b) **Install aluminum spacer provided in the kit onto muffler mount.**
- c) **Install provided exhaust gasket onto Yoshimura tailpipe.**

2. *Installing the muffler tailpipe assembly.*

- a) **Carefully install Yoshimura muffler tailpipe assembly by sliding onto stock header. Re-install stock bolt and washer and secure Yoshimura tailpipe to subframe. Refer to parts diagram.**
- b) **Using the hardware provided, secure Yoshimura muffler onto subframe. See parts diagram for orientation.**
- c) **Torque muffler mount bolts and exhaust clamp to 23 Nm (2.3 kg-m, 16.5 ft-lb).**

3. *Re-install the right side cover.*

- a) **Re-install side cover using the reverse steps of removal.**

4. *Fitment check and Notes.*

- a) **Before starting motorcycle, check for proper clearance between new exhaust system and rear suspension (i.e. tire, swing-arm, brake, rear shock, engine, and etc.) If any problem is found, please carefully follow through the installation steps again. If problem still persists, please call Yoshimura Tech Department at (800) 634-9166 / in CA (909) 628-4722.**
- b) **It is recommended that the muffler and tailpipe be wiped down with rubbing alcohol to remove oil and fingerprints. This will help prevent tarnishing of the finish after the exhaust is heated up.**
- c) **NOTE: After starting motorcycle, it is normal for new exhaust system and muffler to emit smoke until oil residue burns off.**